

R. K. LE BLOND.
MACHINE TOOL.

(Application filed Dec. 22, 1899.)

(No Model.)

4 Sheets—Sheet 1.

Fig. 1.

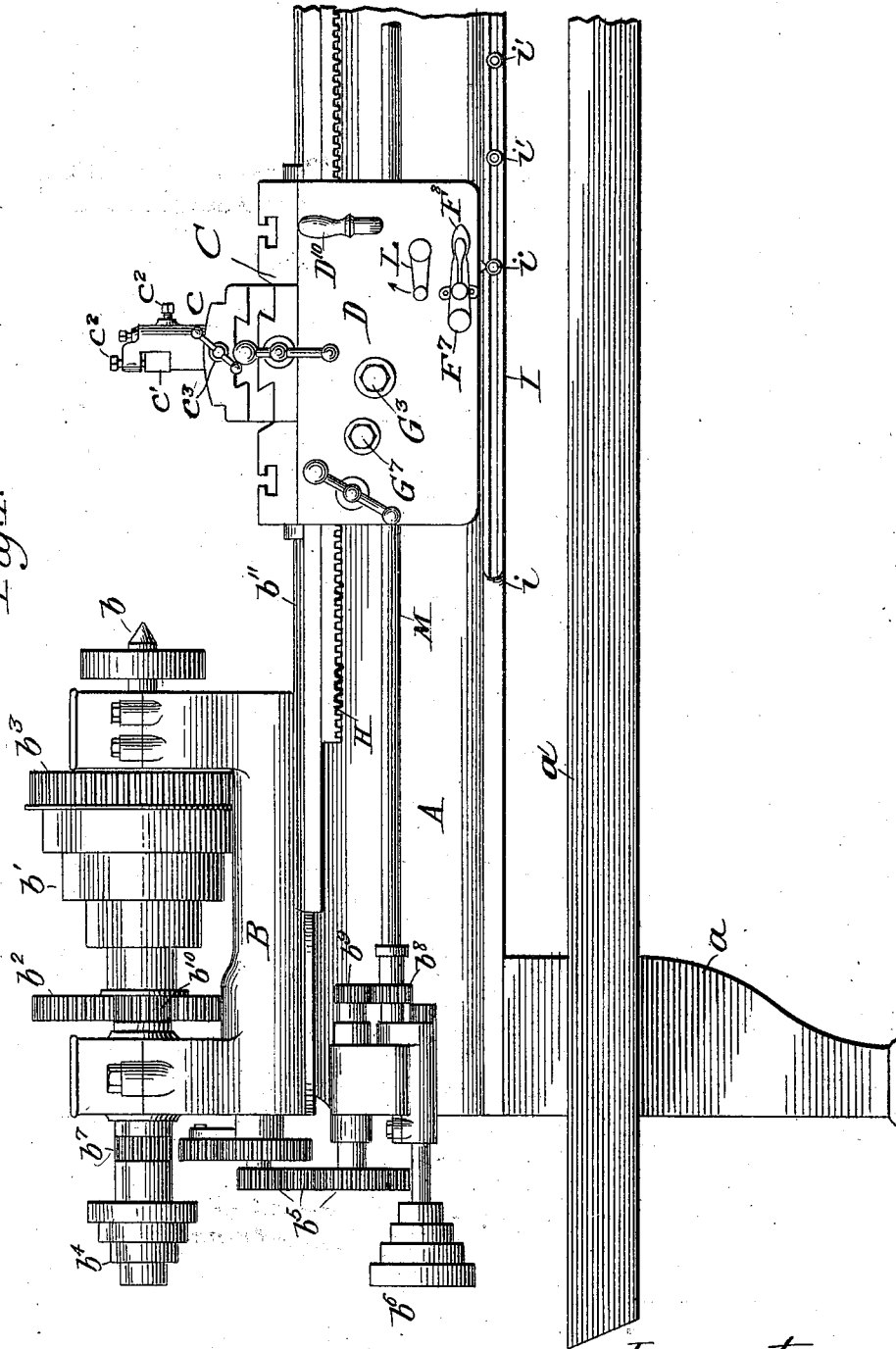

Witnesses:
 O. W. Edelin,
 W. Harvey cutter.

Inventor:
 Richard K. LeBlond.
 By Robt. D. Hains
 atty.

R. K. LE BLOND.
MACHINE TOOL.

(Application filed Dec. 22, 1899.)

(No Model.)

4 Sheets—Sheet 2.

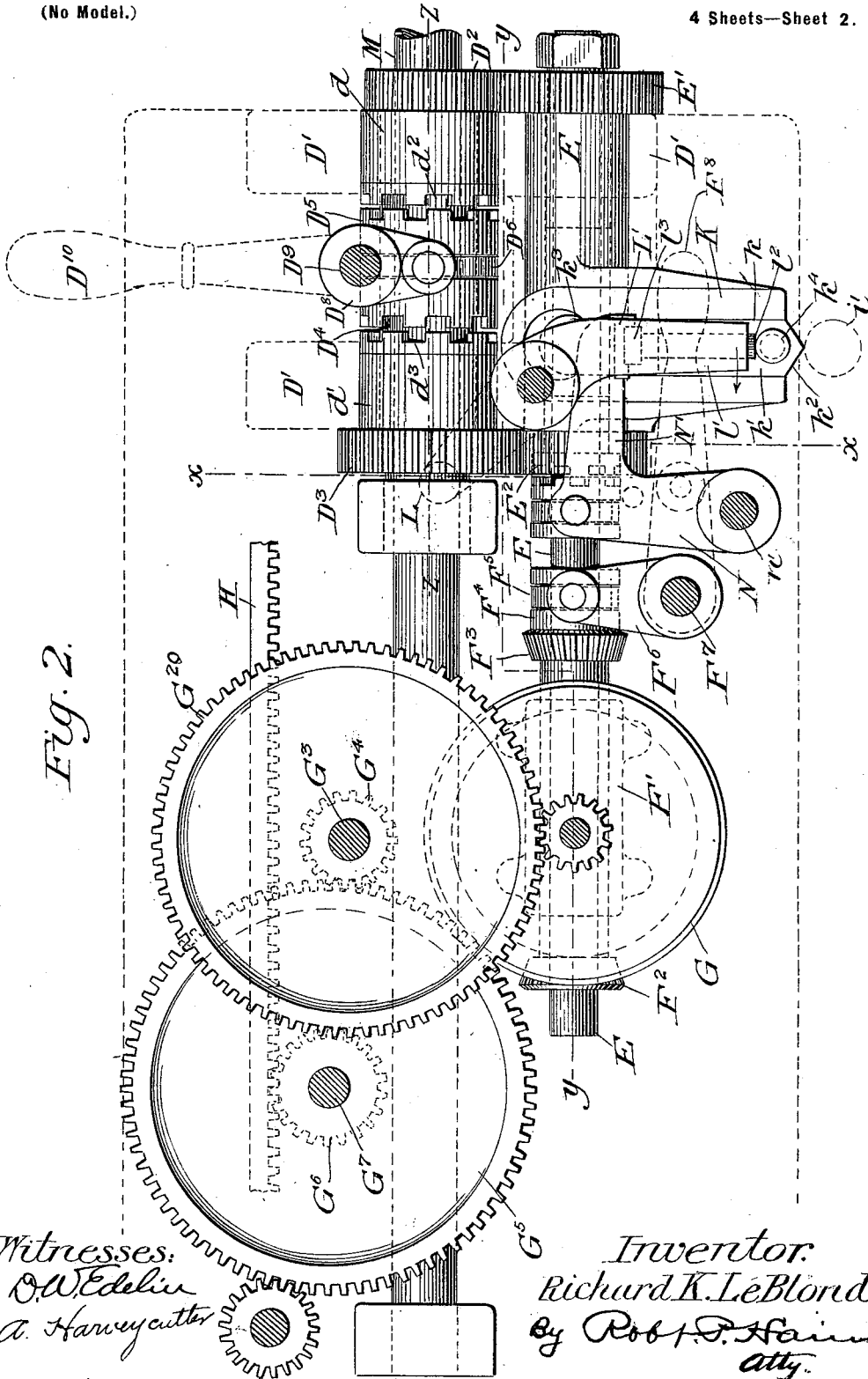

Fig. 2.

Witnesses:
D. W. Edelin
A. Harvey cutter

Inventor:
Richard K. LeBlond.
By Robt. D. Hains
att'y.

R. K. LE BLOND.
MACHINE TOOL.

(Application filed Dec. 22, 1899.)

(No Model.)

4 Sheets—Sheet 3.

Fig. 3.

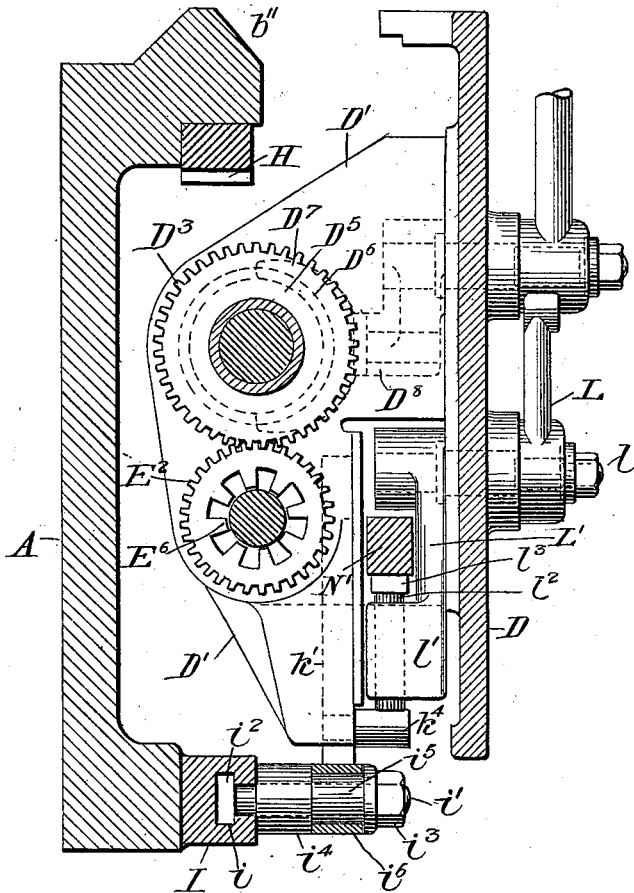
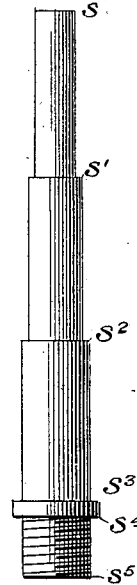

Fig. 6.



Witnesses:
 O. W. Edelin.
 A. Harvey cutter

Inventor:
 Richard K. LeBlond.
 By Robt. D. Sains
 atty

UNITED STATES PATENT OFFICE.

RICHARD K. LE BLOND, OF CINCINNATI, OHIO.

MACHINE-TOOL.

SPECIFICATION forming part of Letters Patent No. 652,788, dated July 3, 1900.

Application filed December 22, 1899. Serial No. 741,275. (No model.)

To all whom it may concern:

Be it known that I, RICHARD K. LE BLOND, a citizen of the United States, residing at Cincinnati, in the county of Hamilton and State of Ohio, have invented certain new and useful Improvements in Machine-Tools, of which the following description, in connection with the accompanying drawings, is a specification.

My invention relates to machine-tools, and as an example of one class to which my invention may be advantageously applied I have selected for illustration an engine-lathe of well-known type equipped with mechanism embodying my improvements in their preferred form. Such form of lathe is particularly adapted for turning, cutting, or otherwise treating spindles and like articles having different diameters in different portions thereof—such, for instance, as crank-pins, spinning-spindles, and all such metallic forms wherein the diameter varies in different portions thereof. When a number of similar spindles or forms are to be turned, the carriage on which the cutting-tool is mounted should be stopped at the same point in treating similar parts of different spindles or forms, and then after the adjustment of the tool the carriage should continue to travel in the same direction until all the parts of the spindle or form have been turned. Otherwise there is much additional work required to bring the spindles or forms into exact similarity in the finishing operation and often considerable loss both of time and material.

With the above in view the object of my invention is to provide means whereby the stopping of the carriage at the same point or points in treating different spindles is absolutely assured and whereby also without disturbing the means that controls such stopping the carriage may be permitted to continue to travel in the same direction to cause the tool to act upon different parts of the spindles; and my invention consists of the parts and combinations, as will be hereinafter more fully described, and definitely pointed out in the claims.

In the drawings, Figure 1 is a side elevation of a sufficient portion of a machine-tool to show my improvements applied thereto. Fig. 2 shows in side elevation and on an enlarged scale the portion of the traveling carriage di-

rectly behind and supported by the apron, the latter being removed but indicated in dotted lines. Fig. 3 is a section on the line xx of Fig. 2. Fig. 4 is a section on line yy of Fig. 2. Fig. 5 is a detail section on the line zz of Fig. 2. Fig. 6 illustrates one of the forms or spindles adapted to be treated by the machine.

In the drawings, A indicates the bed or supporting frame, of any usual or preferred construction, mounted upon uprights or legs a and having the usual trough a' . The head B, carrying the shaft or spindle b , gears b^2 b^3 b^7 b^{10} , and cone belt-pulley b^4 , and the train of gears b^5 , b^8 , and b^9 ; also the cone belt-pulley b^6 and the adjunctive parts, whereby motion is or may be transmitted to the feed-shaft M, are and may be of any usual or preferred construction, and as such devices form no part of my present invention they need no further description.

Mounted to travel on the ways b^{11} of the bed or supporting frame A is the carriage C, upon which is mounted the tool-block c , carrying the cutting or other desired tool c' , which is held to its work by any usual or preferred means, as the clamp-screws c^2 , and adjusted in proper position toward or from the center line of the bed by the hand-screw c^3 or other desired means.

Secured to and depending from the carriage C is the apron D, from which project the brackets $D' D'$, affording exterior bearings for the elongated hubs $d d'$ (shown by dotted lines in Fig. 2 and in detail in Fig. 5) of a pair of different-sized gears $D^2 D^3$, the proximate ends of the hubs being provided with clutch-faces, preferably in the form of notches or recesses $d^2 d^3$. By means of these brackets the gears $D^2 D^3$ are connected to the apron D to travel therewith and yet are free to turn. Passing loosely through the gears $D^2 D^3$ is the feed-shaft M, which, as before explained, receives rotary motion through any usual or preferred means from the head of the machine, and mounted on and splined to the shaft M by the key p between the gears D^2 and D^3 is a sleeve or thimble D^4 , on which and preferably splined to the shaft M by the same key p is the clutch member D^5 , provided with a groove D^6 , which is embraced by a yoke D^7 , Fig. 3. This yoke is mounted on an arm D^8

on the shaft D^9 , whereby it may be thrown either to the right or left by the handle D^{10} to engage the clutch member D^5 with either of the clutch-faces of the gears D^2 or D^3 , the clutch member D^5 being provided with complementary clutch-faces for this purpose, as will clearly appear from Figs. 2 and 3. From the above construction it will be seen that while the gears D^2 and D^3 are loose on the shaft M either of them may be coupled thereto at pleasure by the clutch member D^5 through the handle D^{10} . It will also be noticed that I interpose between the clutch member D^5 and the shaft M a sleeve or thimble D^4 , although I preferably spline both of them to the said shaft by the same key. In practice I have found this sleeve or thimble D^4 desirable to prevent the friction between the clutch member D^5 and shaft M that would otherwise ensue from unclutching said member D^5 from the gears D^2 or D^3 during the travel of the carriage, as will be obvious.

Mounted, preferably, below the feed-shaft M , so as to be carried by the apron D , is the short auxiliary shaft E , on which is loosely mounted the gears E^1 E^2 , fixedly connected by the sleeve E^3 , said sleeve between the gears having an elongated bearing in the brackets D' D' . (See Figs. 3 and 4.) On one end of the shaft E is secured the sleeve E^4 by means of a set-screw e , and bearing against this sleeve at one end and against the reduced portion e^3 of the sleeve E^3 at the other end is a spring S , normally tending to force the shaft endwise in the direction of the arrow, Fig. 4.

The gears E^1 E^2 are preferably of different size, and they intermesh, respectively, with the gears D^2 and D^3 , as shown in Fig. 2. Fast to the shaft E , being secured thereto, as by the pin e^1 , is the clutch member E^5 , having a clutch-face preferably formed of notches or recesses e^2 therein, as shown, which is adapted to be brought into engagement with a complementary clutch-face E^6 on the gear E^2 by the endwise movement of the shaft E in the direction of the arrow, Fig. 4, under stress of spring S .

Splined to the shaft E by the key f is the elongated endwise-movable sleeve F , having a bearing in the bracket F' , Figs. 2 and 4, and carrying at its ends the bevel-gears F^2 and F^3 . One of these gears, as F^3 , preferably has its hub extended to form a recessed collar F^4 , which is engaged by a yoke F^5 , carried by an arm F^6 , mounted on the stud F^7 , Figs. 1 and 2, which is itself journaled in the apron D and carries at its outer end the handpiece F^8 , whereby the yoke, and consequently the collar F^4 and sleeve F , may be moved lengthwise of the shaft E to bring either of the bevel-gears F^2 or F^3 into engagement with the correspondingly-beveled gear G . Fixedly connected to the bevel-gear G is the pinion G^1 , mounted to turn upon a stud or pin G^2 , carried by the apron D . Meshing with the pinion G^1 is the large pinion G^{20} , Fig. 2. Also carried by a stud or pin G^3 , mounted in the apron

D and preferably fixed to pinion G^{20} , is the smaller pinion G^4 , which in turn engages a larger pinion G^5 , mounted on a stud or pin G^7 , carried by the apron. Mounted on the stud or pin G^7 is the feed-pinion G^6 , preferably fixed to the pinion G^5 to receive motion therefrom. This pinion G^6 meshes with the rack II , secured to the frame or bed A , whereby rotary motion given to the pinion G^6 , carried by the apron D of carriage C , causes said carriage to travel along the bed in a direction corresponding to the direction of rotation of the pinion G^6 .

From the mechanism so far described it will be seen that motion from the feed-shaft M is imparted to the gears D^2 or D^3 dependent upon which of said gears is engaged by the clutch member D^5 , and from them it is transmitted to the connected gears E^1 E^2 . If the clutch member E^5 is in engagement with the clutch-face E^6 of gear E^2 , the shaft E will be rotated at a rate of speed dependent upon which of gears D^2 or D^3 is connected to the shaft M by the clutch member D^5 . The size of gears D^2 and D^3 and E^1 and E^2 may be varied as desired, as will be obvious. Motion of the shaft E is transmitted through one or other of the bevel-gears F^2 F^3 , dependent upon the direction of the travel of the carriage desired, to the bevel-gear G , and from thence through the described train of pinions to the feed-pinion G^6 . Thus it will seem that not only can the direction of travel of the carriage be controlled at will by the hand-lever F^8 , but also the rate of such travel in either direction by the hand-lever D^{10} .

Preferably below the carriage C , as indicated in Figs. 1 and 3, is attached or made integral with the frame or bed A a strip I , having a slot i therein, preferably of T shape, in which fit the heads i^2 of arresting devices, preferably in the form of stop-pins i^1 . These arresting devices or stop-pins may be of any desired construction; but I preferably form them with heads i^2 , adapted to the shape of the slot in the strip I , and secure them in any desired position along the strip by means of nuts i^3 , fitted to their outer ends, and I preferably interpose between the face of the strip and the nut a sleeve or washer i^4 , having in its length a reduced portion i^5 , on which is placed a loose ring i^6 , free to turn on said sleeve or washer. It will be evident that by slacking the nut i^3 the stop-pins can be adjusted to any desired position along the strip, and by tightening them the said pins will be held in fixed position. While I have described this as my preferred construction of stop-pins, it is evident that the same may be varied in many ways, and I do not limit myself in this respect, but deem any form of stop-pins in this connection within the scope of my invention.

In order that the arresting devices or pins may remain fixed in their adjusted positions dependent upon the character of spindle or other device being treated and yet act to op-

erate the stopping mechanism or clutch E⁵ in the treatment of any number of spindles, I have provided the following instrumentalities: Loosely mounted in a suitable recess *k* in an extension K of brackets D' or like support, preferably depending from the inside of the apron D, is a stopping-actuator, made in this instance as a slide *k'*, having a beveled lower end *k*³, Fig. 2, and held from moving lengthwise from the recess by any suitable means, as the shape of the recess, which may be slightly enlarged at its upper end to present a shoulder *k*³, as shown in Fig. 2, to be contacted by a corresponding shoulder on the stopping-actuator *k'*. The normal position of this actuator or slide *k'* when not in contact with one of the arresting-pins *i'* presents its lower beveled end slightly below the tops of said pins, from which construction it will be evident that as the carriage moves along the bed A the lower beveled end of the actuator *k'* will contact with the arresting-pins and the actuator be raised thereby. At its lower end the actuator or slide *k'* is provided with a pin or stud *k*⁴, which as the actuator or slide *k'* is moved by contact with the arresting devices or pins *i'* will, through the devices to be hereinafter described, cause the stopping mechanism to be operated to arrest the travel of the carriage.

In order that the movement of the actuator or slide *k'* may be transmitted to the stopping mechanism or clutch member E⁵ and yet the stopping mechanism be readily relieved of such control by the actuator and in order to permit the continued travel of the carriage in the same direction, I have provided the following as a preferred form of trip mechanism: Mounted to turn on the pivot *l*, carried by the apron D, is the bell-crank or trip lever L, having an arm L' located, preferably, directly over the stud or pin *k*⁴. The arm L' has an enlarged lower end *l'*, which is bored or recessed to loosely receive a trip-pin *l*², preferably having an enlarged head *l*³ to prevent the pin falling out of its recess or bearing in the arm L' under the action of gravity. Any upward movement of the actuator or slide *k'* due to contact of its bevel lower end *k*² with an arresting device or pin will cause the stud *k*⁴ to contact with the lower end of pin *l*² and raise it in its loose bearing in the arm L'. Embracing the clutch member E⁵ and traveling in the groove *e*⁴ thereof is the yoke *n*, carried on the upper end of the clutch-arm N, which is pivoted to turn on a stud *n'*, projecting from the apron D. Above its pivotal connection with the apron D the clutch-arm N has a lateral projection N', which normally rests on the head of pin *l*², whereby as the pin is raised by contact of the actuator or slide *k'* with an arresting or stop pin the projection N' causes the clutch-arm N to turn on its pivot, thus moving the clutch member E⁵ and the shaft to which it is attached against the tension of spring S and disengaging the said clutch member E⁵ from the clutch-face gear

E², thereby stopping the feed of the carriage. The trip-pin *l*², being carried by the arm L' of the trip-lever L, is then disengaged from its bearing on the pin *k*⁴ by swinging the arm L' to one side, as indicated by the arrow, Fig. 2. As soon as the pin *l*² is thus freed from the support of pin *k*⁴ it drops until its head *l*³ contacts with the upper part of the enlarged end *l'* of arm L'. This dropping of the pin *l*² frees the projection N', of clutch-arm N, to the action of the spring S, which at once moves the shaft E in the direction of the arrow, Fig. 2, engages the clutch member E⁵ with the clutch-face E⁶ of gear E², and thus continues the feed of the carriage. Movement of the carriage disengages the actuator or slide *k'* from the arresting or stop pin *i'*, whereupon it falls with its lower end below the tops of the arresting or stop pin *i'*, and the parts assume position with the stud *k*⁴ directly below the pin *l*², but not in engagement therewith. The position of the parts is represented in the drawings as having been stopped by contact of the end of the actuator or slide *k'* with the arresting or stop pin *i'*; but the position of said parts during movement of the carriage will be quite evident from the drawings and above description.

In Fig. 6 I have shown one of the many forms of spindles that may be turned by my machine, and in order that the advantages of my stopping and trip mechanism may be fully understood I will proceed to describe the operation of the machine when desired to turn a number of spindles similar to that illustrated.

The blank having been properly clamped as usual between the head and tail pieces, the carriage is moved opposite one end of the blank and the cutting-tool adjusted for the desired depth of cut. The arresting or stop pins *i'* are then adjusted in the piece I, the first one to a point distant from the starting position of the carriage equal to the length of the spindle to the first shoulder *s'*, Fig. 6, the second stop to a point distant from the first stop equal to the length of the spindle between the shoulders *s'* *s*², the third stop to a point distant from the second stop equal to the length of the spindle between the shoulders *s*² *s*³, and so on throughout the entire length of the spindle, as many stops *i'* being placed in position and securely clamped as there are different shoulders or diameter in the length of the spindle. The carriage being now ready to be fed along the bed, the parts are in position with the end of actuator or slide *k'* below the tops of the arresting or stop pins and the projection N' resting upon the upper end of pin *l*², the clutch members E⁵ and E⁶ being thus held in engagement by spring S, and the hand-lever F³ is manipulated to throw one or the other of the bevel-gears F² F³ into engagement with the gear G, according to the direction of travel desired. The clutch member D⁵ is then thrown into engagement with one of the gears D² D³, ac-

cording to the speed required, and the carriage at once begins to travel along the bed. Upon reaching the first arresting or stop pin i' , which marks the position of the first shoulder on the spindle, the beveled end k^2 of the actuator or slide k' strikes the pin, lifting the actuator or slide, and by means of stud k^4 raises the loose pin l^2 in its bearing, thus raising the projection N' of the clutch-lever N and disengaging the clutch member E^5 from the clutch-face E^6 of gear E^2 and stopping the feed or movement of the carriage. The tool is then adjusted, if necessary or desirable, and the bell-crank on trip-lever L is swinging to one side, as indicated by arrows in Figs. 1 and 2, thereby releasing the trip-pin l^2 from the support of stud k^4 and permitting the projection N' of clutch-lever N to drop and the spring S to act to engage the clutch members E^5 and E^6 , whereupon the carriage continues to travel to the next stop, which marks the second shoulder on the spindle, when the operation of stopping and starting is repeated. By this construction it will be seen that the arresting or stop pins i' determine with absolute accuracy the point of stopping of the carriage, and as they may when once adjusted to position remain undisturbed they insure the absolute similarity of all the spindles or similar devices treated.

While I have described the stopping-actuator as a slide, it is quite evident that the construction may be varied, it being only necessary that the actuator may be of such construction as that it may be moved by contact with the arresting or stop pins and carried over or past them upon continued movement of the carriage. Likewise I have shown the trip mechanism as a loose pin carried by an arm of a bell-crank lever; but as its function is to trip or free the stopping mechanism of control of the actuator, to thereby permit the continued movement of the carriage in the same direction without disturbing the adjustment of the arresting devices or pins, I do not desire to be understood as limiting my invention to the construction described, as it may be varied without departing from the spirit of the invention.

Having thus described my invention, what I claim, and desire to secure by Letters Patent, is—

1. In a machine-tool, the combination of a supporting-frame, a carriage movable thereon, and carrying a tool, means for moving the carriage along the frame, and stopping mechanism, means for actuating the stopping mechanism to stop the carriage at a predetermined point in its travel, and devices for tripping said means to permit the carriage to continue its travel in the same direction from the said predetermined point to continue the action of said cutting-tool.

2. In a machine-tool, the combination of a supporting-frame, a carriage movable thereon, and carrying a cutting-tool, means to move the carriage along the frame, an arresting de-

vice, a stopping mechanism, a stopping-actuator adapted to contact with said arresting device and thereby actuate the stopping mechanism to stop the travel of the carriage at a predetermined point, and means to free the stopping mechanism from control of said actuator to permit the carriage to continue its travel from said point to continue the action of said cutting-tool.

3. In a machine-tool, the combination of a supporting-frame, a carriage movable thereon and carrying a tool, adjustable arresting devices mounted on said frame, a stopping mechanism, a stopping-actuator adapted to contact with said arresting devices and be moved thereby, and means to free the stopping mechanism from control of said stopping-actuator to permit the carriage to continue to travel from the point at which it was stopped by contact of the actuator and arresting device to continue the action of said tool.

4. In a machine-tool, the combination of a supporting frame or bed, a carriage movable thereon, arresting devices mounted on said frame or bed, a stopping mechanism, a stopping-actuator adapted to contact with the said arresting devices and be moved thereby, trip devices interposed between the stopping mechanism and actuator to transmit movement of the latter to the former, and means for freeing said devices from control of the said actuator.

5. In a machine-tool, the combination of a supporting frame or bed, a carriage movable thereon and carrying a tool, a stopping mechanism mounted on said carriage, means for actuating said stopping mechanism at predetermined points in the travel of said carriage to stop the carriage, and devices for tripping said means to permit the carriage to continue its travel in the same direction from said point to continue the action of said tool.

6. In a machine-tool, the combination of a supporting frame or bed, adjustable pins mounted on said frame or bed, a carriage movable along the frame or bed, a stopping mechanism, a stopping-actuator controlling the action of said stopping mechanism, and having a part adapted to contact with said pins to thereby move the actuator and operate the stopping mechanism and a trip device interposed between the stopping mechanism and actuator to free the former from control of the latter when desired.

7. In a machine-tool, the combination of a frame or bed, arresting-pins mounted thereon, a carriage, means including a clutch for moving said carriage along the bed, devices operative by contact with the arresting-pins to disengage the clutch and stop the travel of the carriage at a desired point, and means for freeing the clutch from the control of said devices to permit the carriage to continue its travel from said point.

8. In a machine-tool, the combination of a frame or bed, a carriage movable thereon, a

stopping mechanism, arresting-pins mounted on the frame or bed, a stopping-actuator for controlling the action of said stopping mechanism, and adapted to engage said arresting-pins, and a trip device comprising a lever, a pin controlled thereby and interposed between the stopping mechanism and actuator.

9. In a machine-tool, the combination of a frame or bed, arresting-pins mounted on said frame or bed, a carriage, means including a clutch for moving said carriage along the bed, a spring for normally holding the clutch members in engagement, a stopping-actuator adapted to contact with and be moved by said arresting-pins, devices interposed between the actuator and clutch to transmit motion of the former to the latter, and a trip to free the clutch from control of the actuator.

10. In a machine-tool, the combination of a frame or bed, a carriage movable along the same, an apron connected to said carriage, mechanism including a clutch for controlling the movement of said carriage and mounted on said apron, arresting-pins mounted on the

frame below the apron, a stopping-actuator having an end projecting below the apron and adapted to contact with said arresting-pins, motion-transmitting devices interposed between the clutch and actuator, and a hand-operated trip for freeing the clutch from control of the actuator after it has been operated thereby.

11. In a machine-tool, the combination of a frame or bed, a feed-shaft, a carriage movable along the bed and carrying gears loosely mounted on said shaft, said gears having clutch-faces, a sleeve or thimble interposed between the ends of said gears, a clutch member also interposed between said gears and mounted on said sleeve or thimble, said clutch member and sleeve or thimble being splined to said shaft and means connected to each of said gears for moving the carriage.

RICHARD K. LE BLOND.

Witnesses:

A. HARVEY CUTTER,
FRANCES O'REAR.